

PWS3.x (SCR Based) / HS-PWS (IGBT Based) Eddy Current Power Supply with Current Control



Contents

SportDevices End User License & Warranty Disclaimer.....	2
General Safety Instructions	3
SAFETY: When Working Inside Your Device	4
SAFETY: General Power Safety	4
SAFETY: If Your Device Gets Wet	4
SAFETY: If You Drop or Damage Your Equipment.....	5
Protecting Against Electrostatic Discharge.....	5
Technical Specs	7
Connections for Brake Power Supply PWS3.1 (GEN 3) (FW1.11).....	8
Configuration Procedure	8
Connections for Brake Power Supply PWS3.2 (GEN 3)	9
Configuration Procedure	9
PWS3.3	10
HS-PWS High Speed Power Supply (IGBT @ 1KHz).....	11
Jumpers for HS-PWS.....	14
CAN Connections and CAN ID configuration	16

SportDevices End User License & Warranty Disclaimer

DISCLAIMERS

Limitations of warranties and liability: This Power Supply, including its embedded firmware, is provided and licensed by SportDevices on an "as is" basis, without any other warranties or conditions, express or implied, including, but not limited to, warranties of merchantable quality, satisfactory quality, merchantability or fitness for a particular purpose or non-infringement, or those arising by law, statute, usage of trade, course of dealing or otherwise. The entire risk as to the results and performance of this product is assumed by you. To the maximum extent permitted by applicable law, neither SportDevices, its dealers or suppliers shall have any liability to you or any other person or entity for any indirect, incidental, special, or consequential damages whatsoever, including, but not limited to, loss of revenue or profit, lost or damaged data or other commercial or economic loss, even if SportDevices has been advised of the possibility of such damages, or they are foreseeable. SportDevices is also not responsible for claims by a third party. Other possible damages **INCLUDE VEHICLE OR ENGINE DAMAGES, DYNAMOMETER DAMAGES, AND PERSONAL INJURIES**. The limitations set forth herein shall apply whether or not the alleged breach or default is a breach of a fundamental condition or term or a fundamental breach.

Any disputes arising between the parties over any products, services, warranties, terms, agreements, etc. shall be governed under the laws of Valencia (Spain) and in an appropriate court within its jurisdiction.

This Product License Warranty Disclaimer supersedes all prior warranty statements. Inquiries concerning this Product Warranty Disclaimer should be directed to:

SportDevices

Cami del Port 145, 46470 Catarroja, Spain

General Safety Instructions

Use the following safety guidelines to help ensure your own personal safety and to help protect your equipment and working environment from potential damage.

SAFETY: General Safety

When setting up the equipment for use:

- Place the equipment on a hard, level surface. If the equipment is installed in a closed-in wall unit, ensure that there is enough ventilation.
- Avoid placing objects on top of this equipment to permit the airflow required for proper ventilation. Restricting airflow can damage the equipment.
- Keep your device away from radiators and heat sources.
- Keep your equipment away from extremely hot or cold temperatures to ensure that it is used within the specified operating range. (check technical parameters section)
- Keep your equipment away from Electromagnetic emitting devices like CDI ignition, or electric motors / VFD (Variable Frequency Drive)
- Do not push any objects into the air vents or openings of your equipment. Doing so can cause fire or electric shock by shorting out interior components.
- Ensure that nothing rests on your equipment's cables and that the cables are not located where they can be stepped on or tripped over.

When operating your equipment:

- Installation place must be dry, cool and **free of strong vibrations**.
- Ensure that ventilation is enough; if necessary drill the enclosure to ease ventilation.
- Do not use AC powered equipment during an electrical storm.
- Do not spill food or liquids on your equipment.
- Before you clean your equipment, disconnect it from the electrical outlet. Clean your device with a soft cloth dampened with water. Do not use liquids or aerosol cleaners, which may contain flammable substances.
- Clean the display with a soft, clean cloth and water. Apply the water to the cloth, then stroke the cloth across the display in one direction, moving from the top of the display to the bottom. Remove moisture from the display quickly and keep the display dry.
- Long-term exposure to moisture can damage the display. Do not use a commercial window cleaner to clean your display.



CAUTION: Do not operate your equipment with any cover(s) removed.

- If your equipment does not operate normally - in particular, if there are any unusual sounds or smells coming from it - unplug it immediately and contact an authorized dealer or service center.



WARNING: To prevent the spread of fire, keep open flames away from this product at all times.

SAFETY: When Working Inside Your Device



Do not attempt to service the equipment yourself, except as explained in your documentation or in instructions otherwise provided to you by SportDevices. Always follow installation and service instructions closely.

The only user configurable parts in this device are: jumpers and wiring.

All parts in this equipment are powered to grid, even the low voltage parts as LCD, switches, jumpers, BT dongle (when present), etc, are directly connected to grid. Do not touch any of the electrical parts unless the circuit breaker it OFF.

SAFETY: General Power Safety

Voltages used in this device are capable of killing a person! Read carefully this section.

-  By default, if other values are not specified, all SportDevices equipment are rated for **230 VAC / 50 Hz**. (115 VAC units will have a specific label for that)
-  **All parts in this equipment are powered to grid**, even the low voltage parts as LCD, switches, jumpers, BT dongle (when present), etc, are directly connected to grid. Do not touch any of the electrical parts unless **the circuit breaker it OFF**.

Observe the following guidelines when connecting your equipment to a power source:

- Check the voltage rating before you connect the equipment to the grid to ensure that the required voltage and frequency match the available power source.
- This equipment is designed to have a permanent installation to the grid through a **circuit breaker and a differential switch**.
- Ensure both power lines (L and N) are correctly connected to the 230 V input connector, **and ground cables are correctly connected to ground screws**.
- **Brake and dynamometer must not be operated without the GND cable installed and a differential switch.**
- **All wires must be in good condition and the brake must not have leakages**. Note that some brakes from junk yard may have current leakages and **must not be used** until coils are verified and repaired.
- **Dynamometer must have its own GND cable directly to the grid, as the brake is floating over bearings and may not have enough protection in case some of the wires are in bad condition and touching the dynamometer chassis.**
- Connection can also be made through a power cord, but ensure the power cord rating is suitable for the brake application (typically 16 Amp or higher), **and ground is correctly connected from the equipment to building Ground and to brake and dynamometer.**

SAFETY: If Your Device Gets Wet

- ⚠ **CAUTION: Before you begin any of the procedures in this section, see the SAFETY: General Safety section of this document.**

⚠ CAUTION: Perform this procedure only after you are certain that it is safe to do so. If the device is connected to an electrical outlet, turn off the AC power at the circuit breaker, if possible, before attempting to remove the power cables from the electrical outlet. Use the utmost caution when removing wet cables from a live power source.

1. Disconnect the AC cord from the electrical outlet, and then, if possible, disconnect the AC cord from the device.
2. Turn off any attached external devices, then disconnect them from their power sources, and then from the device.
3. Contact SportDevices support (info@sportdevices.com)

⚠ Limited Warranties: warranty is limited to normal usage of the device, any fault caused by inappropriate usage or accident will not be covered

SAFETY: If You Drop or Damage Your Equipment

⚠ CAUTION: Before you begin any of the procedures in this section, see the **SAFETY: General Safety and Power Safety** sections of this document.

4. CAUTION: If any internal components can be seen through damaged portions, or if smoke or unusual odors are detected, disconnect the device from the electrical outlet and contact SportDevices support (info@sportdevices.com)

1. Save and close any open files, exit any open programs, and shut down the computer.
2. Turn off the device and disconnect from the power source, and then disconnect from the computer.
3. Turn off any attached external devices, and disconnect them from their power sources and then from the computer.
4. Connect the device to the power source and turn on the device.
5. If the device does not start, or if and smoke or unusual odors are detected, or you cannot identify the damaged components, contact SportDevices support.

Protecting Against Electrostatic Discharge

⚠ CAUTION: Disconnect product from mains power source in accordance with product specific safety information located on the “Safety Information” section of this website.

Electrostatic discharge (ESD) events can harm electronic components inside your device. Under certain conditions, ESD may build up on your body or an object, such as a peripheral, and then discharge into another object, such as your device. To prevent ESD damage, you should discharge static electricity from your body before you interact with any of your device’s internal electronic components, like the Bluetooth plug-in.

You can protect against ESD and discharge static electricity from your body by touching a metal grounded object (such as an unpainted metal surface on your device) before you interact with anything electronic.

You can also take the following steps to prevent damage from electrostatic discharge:

- When unpacking a static-sensitive component from its shipping carton, do not remove the component from the antistatic packing material until you are ready to install the component. Just before unwrapping the antistatic package, be sure to discharge static electricity from your body.
- When transporting a sensitive component, first place it in an antistatic container or packaging.
- Handle all electrostatic sensitive components in a static-safe area. If possible, use antistatic floor pads and work bench pads.

Technical Specs

Input:

- Supply Voltage: 230 Vac / 50-60 Hz. Single phase. **For PWS3.x: Max one Power Supply per phase, use different phases for AWD operation.**
- Power Consumption: 16 Amp brake: max 3.2 KW, 23 Amp brake: max 4.6 KW

Output:

- **Max Brake Voltage:** 200 VDC, 100 VDC, 70 VDC, 50 VDC

PWS3.x

- Modulation Method: Phase Angle Control (SCRs) @ 100 Hz
- Inductive Load Control: Flywheel diode (passive discharge)
- **Max Brake Current:** up to 21A or 40A depending on the model

HS-PWS

- Modulation Method: PWM (IGBTs) @ 1000 Hz
- Inductive Load Control: Flywheel diode (passive discharge)
- **Max Brake Current:** up to 21A

HS-PWS-Discharge

- Modulation Method: PWM (partial H-bridge topology) @ 1000 Hz
- Inductive Load Control: Regenerative discharge (-200VDC) + Overvoltage Control

Control lines:

- **PWM input:** PWM 0 to 5 Volt, 2.4 Khz. ISOLATED:
 - + Brake output (SP4/SP5)
 - - GND
- **Analog input (* optional):** 0 to 5 Volt. ISOLATED:
3 pin connector
 - Pin 1: GND
 - Pin 2: Analog in
 - PIN 3: 5V (low current for potentiometer)

Other:

- Working Conditions: Temperature: -10°C to 40°C, humidity < 90%
- Storage Conditions: Temperature: -20°C to 80°C, humidity < 80%
- Current Control: P.I. regulator (Proportional Integral)

Connections for Brake Power Supply PWS3.1 (GEN 3) (FW1.11)

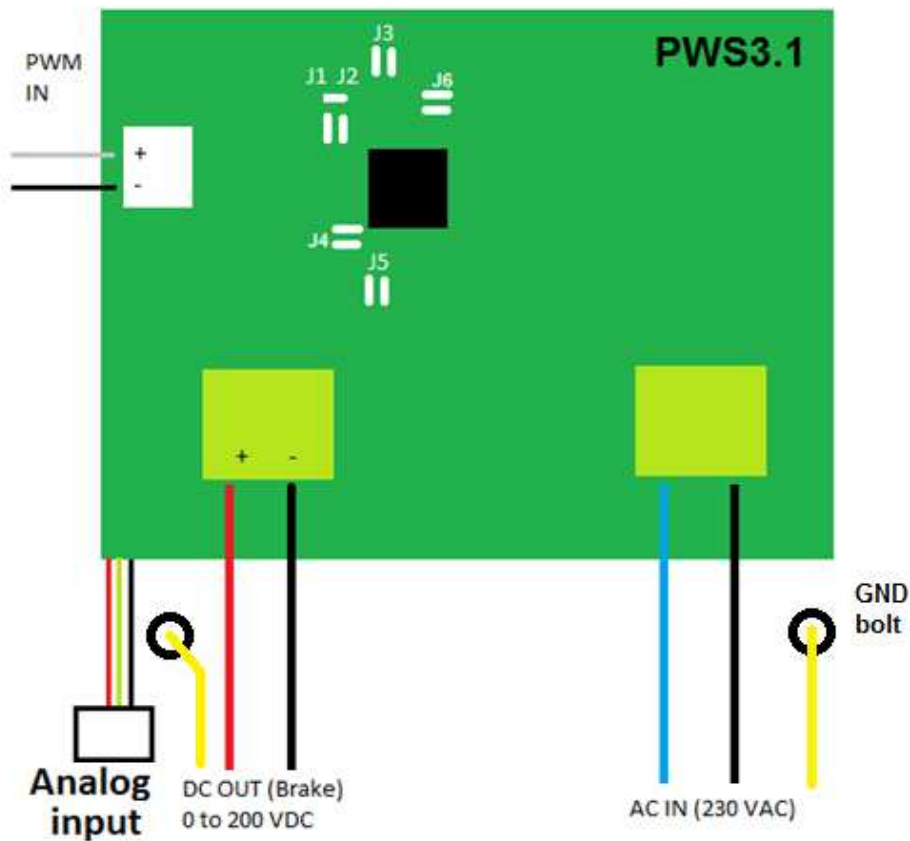

Note: **brake must not be operated without the GND wire.** If brake has leakages it must be repaired before using it with the Power Supply

Configuration Procedure

- **Disconnect PWS3.1 from grid**
- Remove Plastic box screws (4)
- Remove LCD display nuts and washers (2 + 2), and then LCD Display
- Locate solder Jumpers (J1 to J5)

Voltage	J1 (half)	J2 (half)	Current)	J3	J4	J5
200 VDC	OFF	OFF	29-Amp (not available)	OFF	OFF	OFF
100 VDC	ON	OFF	23-Amp	ON	OFF	OFF
70 VDC	OFF	ON	20 Amp	OFF	ON	OFF
50 VDC	ON	ON	16 Amp	ON	ON	OFF
			12 Amp	OFF	OFF	ON
			9 Amp	ON	OFF	ON
			7 Amp	OFF	ON	ON
			4 Amp*	ON	ON	ON

Note 1: jumpers are ON by placing a solder drop, and OFF when empty

Note 2: Table valid for FW version 1.11+

Note 3: **modes higher than 21A are not safe**, for currents up to 25A a modification is possible, please contact us.

Note 4: *4 Amp only valid for special HW configuration (1 shunt instead 2 shunts)

- Assemble PWS3.1 again and Power It up, the starting message will show the current configuration (50, 70, 100, 200 V and selected current)

Connections for Brake Power Supply PWS3.2 (GEN 3)

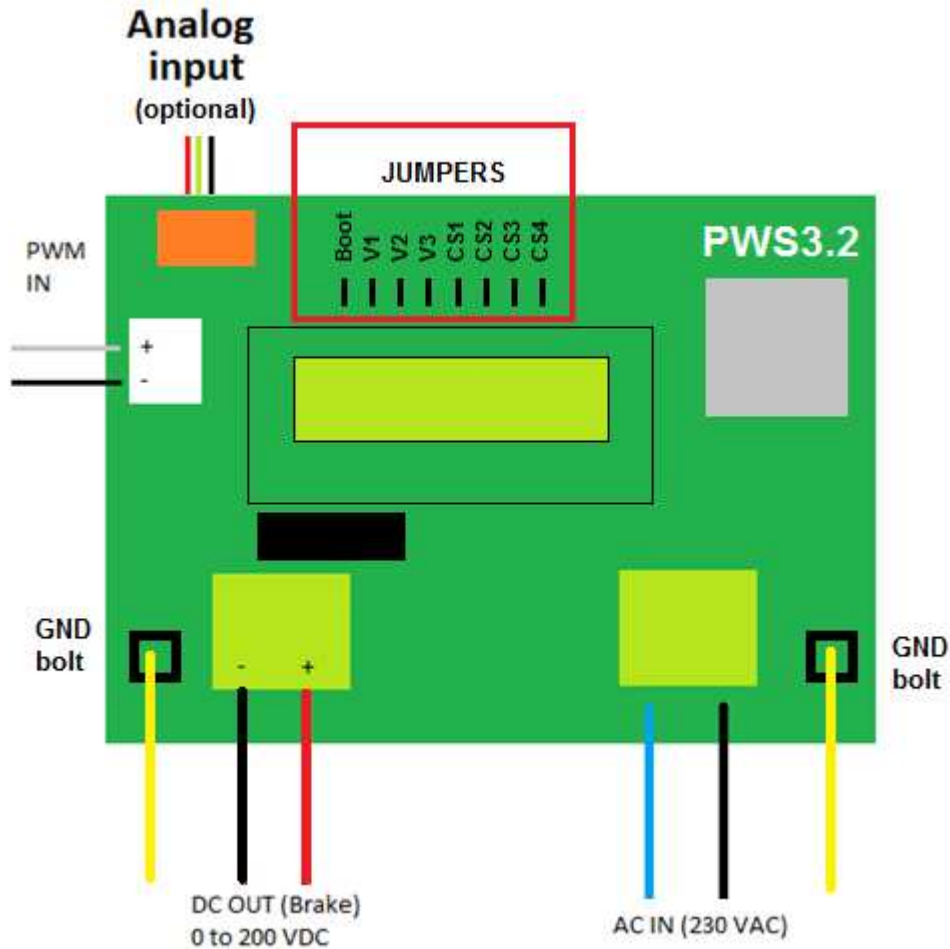

Note: **brake must not be operated without the GND wire.** If brake has leakages it must be repaired before using it with the Power Supply

Note that for Firmware versions from 2.18 and 3.18 (and later) it is **NO LONGER NECESSARY** to use the jumpers, just keep all open (they come open by default) and use the methods 2 or 3 described below to configure your PWS for your brake

Configuration Procedure

- **Disconnect PWS3.2 from grid**
- Remove Plastic box screws (4)
- There are 3 methods to configure the power supply:
 1. Or using **Jumpers** according to the table below
 2. Using the **USB connector** (all jumpers open)
 3. **Using the brake measuring tool** (press SELECT switch) (all jumpers open)

1. Jumpers Configuration (no longer necessary from FW 2.18 and 3.18)

Note that for methods 2 and 2 (USB and measuring tool) all jumpers must be open. This work for FW versions 2.18 and 3.18

PWS3.2

Voltage	VS1	VS2	VS3	Current	CS1	CS2	CS3	CS4
200 VDC	-	OFF	OFF	EEPROM *	OFF	OFF	OFF	-
100 VDC	-	ON	OFF	23 Amp	ON	OFF	OFF	-
70 VDC	-	OFF	ON	20 Amp	OFF	ON	OFF	-
50 VDC	-	ON	ON	16 Amp	ON	ON	OFF	-
				12 Amp	OFF	OFF	ON	-
				9 Amp	ON	OFF	ON	-
				7 Amp	OFF	ON	ON	-
				4 Amp*	ON	ON	ON	-

Note 1: jumpers are ON by placing the jumper between pins, and OFF when is not set

Note 2: For PWS3.2 modes higher than 21A are not safe!. For currents up to 25A a modification is possible, please contact us.

Note 3: When all jumpers are OPEN the configuration is taken from the EEPROM

Note 4: *4 Amp only valid for special HW configuration (1 shunt instead 2 shunts)

- Assemble PWS3.2 again and Power It up, the starting message will show the current configuration (50, 70, 100, 200 V and selected current)

PWS3.3

J2/40A jumper is OFF and Semikron is 28A model: same table as for PWS3.2

J2/40A jumper is ON and Semikron is 40A model

Voltage	VS1	VS2	VS3	Current	CS1	CS2	CS3
200 VDC	-	OFF	OFF	EEPROM *	OFF	OFF	OFF
100 VDC	-	ON	OFF	35 Amp	ON	OFF	OFF
70 VDC	-	OFF	ON	32 Amp	OFF	ON	OFF
50 VDC	-	ON	ON	28 Amp	ON	ON	OFF
				25 Amp	OFF	OFF	ON
				21 Amp	ON	OFF	ON
				19 Amp	OFF	ON	ON
				16 Amp	ON	ON	ON

Note: When all jumpers are OPEN the configuration is taken from the EEPROM

2. Configuration using USB connector

- **Note that for methods 2 and 3 (USB and Measuring Tool) all jumpers must be open. This work for FW versions 2.18 and 3.18**
- Check that the **USB / BT jumper** is in the USB position (it should be its default position)
- Connect the PWS to the computer using a **printer USB cable**
- **Open External Data Sources Window** in SportDyno (you may need to enable it at Advanced Options)
- **Choose the COM** installed when connecting the USB cable (you may need the FTDI drivers). When the connection is active it will show voltage and current in the black box
- **Read max Voltage and Max Current** values to check the communication
- **Modify max Voltage and Max Current** them according to your application and press **Store Config**. Note that despite any voltage is allowed (from 1 to 200V) for voltages below 50V the accuracy can be low.
- **Verify (read config)** that the values are correctly stored. These values will be shown in the LCD the next time the PWS is restarted

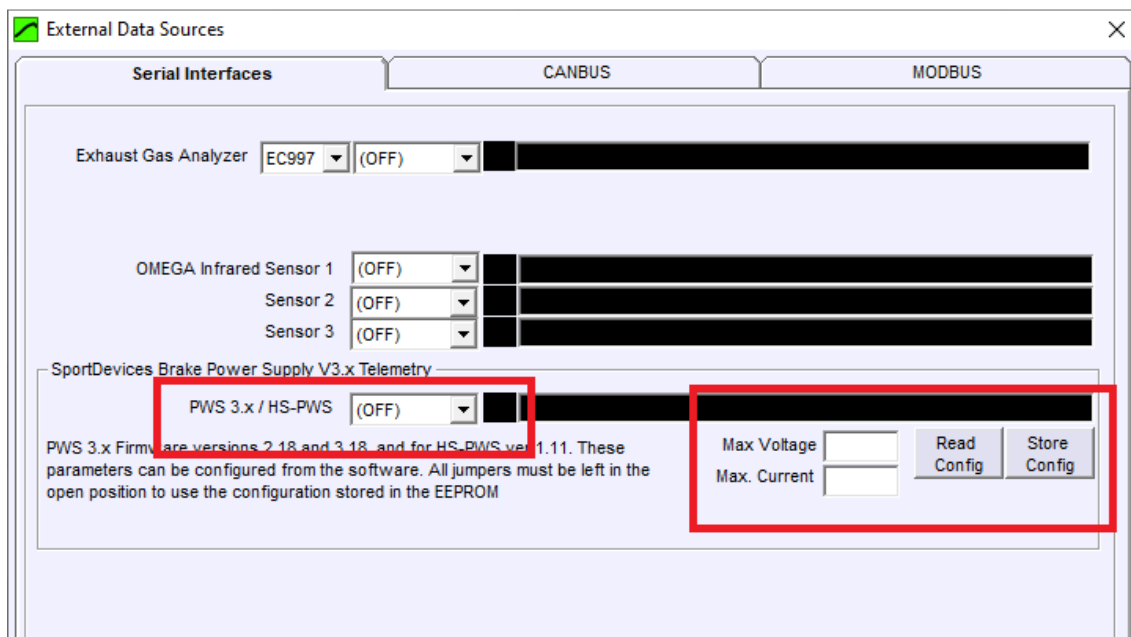

3. Configuration using the Measuring Resistance Tool

- **Note that for methods 2 and 3 (USB and Measuring Tool) all jumpers must be open. This work for FW versions 2.18 and 3.18**
- **Connect** the power and brake to the PWS as usually
- Start the PWS
- **NOTE that all switches are NOT isolated from the grid, it is better to use a plastic tool to press them.**
- When the PWS completes its startup, **press the SELECT button**, the measuring process will start, the LCD will show **"Measuring RES. "**
- **The PWS will apply approx 50V to the brake for a few seconds. If this voltage is not ok for your brake don't use this method**
- At the end of the measurement the PWS **will show the measured resistance**, and the recommended current for 200VDC setting. For instance for a resistance of 10.0 Ohm it will choose 200V and 20A settings:
 - **"Res = 10.0 Ohm"**
 - **"MAX 200 V, 20 A"**
- **If the resistance is below 9 Ohm it will assume that the brake is rated for 96V! . This can be a problem for CFK-550 brake models that are rated for 25A (aprox 8 ohm), in this case you should use the USB configuration manually (previous section)**
- The LCD will show **"SELECT to Store "**, if you press **SELECT** again it will store the current settings. If you wait a few seconds or press the switch **MENU** it will cancel the measurement & store process



HS-PWS High Speed Power Supply (IGBT @ 1KHz)

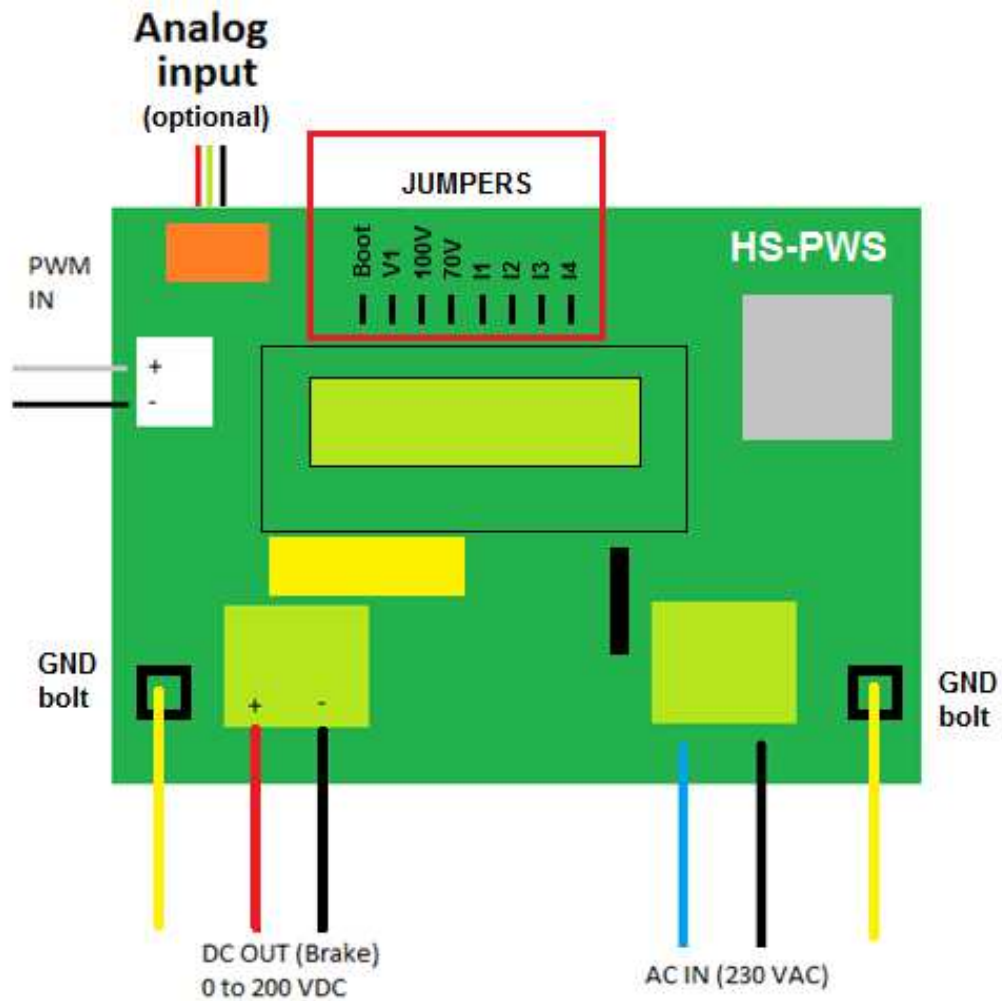

Note: **brake must not be operated without the GND wire.** If brake has leakages it must be repaired before using it with the Power Supply

PWS rectifies AC on a DC bus, and then DC is applied through an IGBT transistor to the eddy current brake changing duty cycle (PWM) at 1000 Hz which provides a slightly faster control than PWS3.x and less ripple on the current output.

Jumpers for HS-PWS

Note that for Firmware version from 1.11 (and later) it is **NO LONGER NECESSARY** to use the jumpers, just keep all open (they come open by default) and use the methods 2 or 3 (BT or Measuring Tool) as for PWS3.2 and PWS3.3 (check the previous section).

Note HS does not have USB port, it can be only connected by Bluetooth (with a pre-configured dongle).

Voltage	"100V"	"70V"	Current)	I1	I2	I3
200 VDC	OFF	OFF	EEPROM*	OFF	OFF	OFF
100 VDC	ON	OFF	23 Amp	ON	OFF	OFF
70 VDC	OFF	ON	21 Amp	OFF	ON	OFF
50 VDC	ON	ON	16 Amp	ON	ON	OFF
			12 Amp	OFF	OFF	ON
			8 Amp	ON	OFF	ON
			6 Amp	OFF	ON	ON
			4 Amp	ON	ON	ON

Note 1: Table valid from FW version 1.05, from 1.11 the "all open" setting will access to the EEPROM values

Note 2: *4 Amp Mode is not accurate with HS-PWS due to the hysteresis of the Current Hall Sensor (does not use shunts as PWS3.x do)

Note 3: * When all jumpers are OPEN the configuration is taken from the EEPROM

Differences between PWS3.x and HS-PWS power supplies

Due to the high inductance of eddy current brakes, power supply provides a control based on current (it applies high voltages during transients to reduce the time response). **Nevertheless, a transient from 0% to 100% is always slow, as it is limited by the brake (up to 500 ms)**

Most power supplies feed the brake directly from grid using SCRs (thyristors) which actively rectify AC on DC for the brake. This topology has several advantages: robustness, simplicity, constant load on the AC grid (no current peaks). On the other hand, SCRs need to be synchronized with the grid frequency, this limits the control frequency to 100 Hz (Europe) / 120 Hz (USA), this makes control performance slightly poorer than HS-PWS.

In HS-PWS, AC is rectified to DC and then it is applied to the brake using an IGBT transistor (PWM). Our HS-PWS operates at 1000 Hz to minimize interferences. This provides a faster control than PWS3.x

HS-PWS has several advantages: More linear output, low ripple current, more accurate and faster control on transients. On the other hand HW-PWS has the following disadvantages: more heat dissipation, more electric interferences on the load cell, audible operation.

To summarize: all power supplies have an initial delay caused by the brake, but HS-PWS provides more accurate control during small transients and clean current. Nevertheless, due to the lower interferences, PWS3.x are being improved to be able **replace HS-PWS**.

What is HS-PWS-D (discharge)? Power supplies can charge the brake fastly, but when the discharge is required they passively discharge the brake through a flywheel diode. Although discharge is fast at the range from 100% to about 20% of brake range, **when 20% is reached discharge may become extremely slow (up to 5 seconds)**. HS-PWS-D is able to regenerate the stored energy and dissipate the voltage excess using resistors. This consumes the brake energy very fast and provides an accurate control on brake de-energizing process.

When is this useful? Actually, **for most dynamometers this is almost NOT noticeable** as they normally operate in the recommended region (approx 20% to 80%) and especially on roller dynos, whose inertia minimizes the effect of the remaining brake torque. But for HUB dynos, and **engine dynamometers** with big brakes and small engines and low inertia, it can make a difference as the brake can operate in the 0% to 20% range and remove the remaining torque very fast.

	PWS3.x	HS-PWS (to be discontinued)	HS-PWS-D (discharge) (new)
Modulation Method	SCRs (synchronized with grid frequency)	IGBT with DC bus	IGBT, partial H-bridge
Control Frequency	100/120 Hz (Europe/USA)	1000 Hz	1000 Hz
Voltage control	Not linear (AC input)	Linear	Linear
Inductive Load Control	Flywheel diode (passive discharge)	Flywheel diode (passive discharge)	Regenerative discharge + Overvoltage Control
Interferences Emission	Low (100 Hz rectified)	Medium (1000 Hz square wave)	Medium (1000 Hz square wave)

CAN Connections and CAN ID configuration

The CANBUS has a BUS topology (star net is not possible). This means that there is one first unit (SP5 / 6), zero or more intermediate units, and a last unit. Both first and last units have the “Terminator” Jumper active to avoid “echoes” in the line. SP5 / 6 have an internal fixed terminator that cannot be disabled, while the PWS have a jumper to disable all of the intermediate units, and leave only the last one

Each PWS provides a PWM cable used to command the PWS from the SP5/6 in an “analogue” way, and a CANBUS connector to command and have feedback from the PWS into the DAQ.

Despite in some version both cables may work at same time, **in general ONLY ONE one of these cables should be connected a time**, otherwise small delays caused by filtering and differences in sampling (in the data coming from each channel) may cause erratic operation specially in engine dynamometers

CAN power: in order to provide a total isolation between the DAQ and the Power Grid several optocouplers are used in the Analog, PWM and CAN lines. For CAN we use a specific isolated transceiver, but this transceiver needs external power.

- In **PWS3.2** this power had to come from SP5/6, this makes necessary to use 4 lines for the CANBUS, and it is recommended to a shielded cable
- In **PWS3.3** power is taken from the internal DC/DC, and only the GND line. VCC line can be discarded. We recommend use GND (although in theory CAN could work with only the differential lines CAN_H and CAN_L) to avoid problems with high spikes / interferences

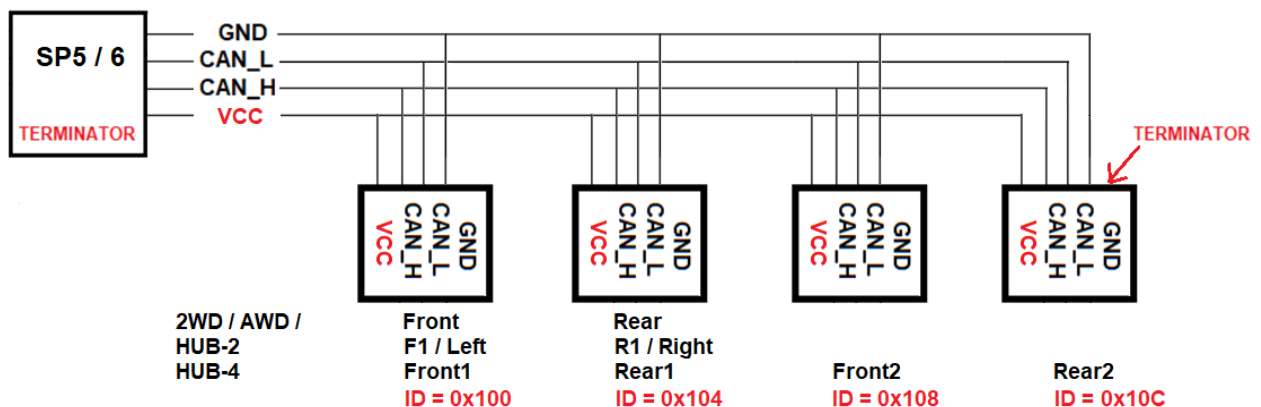
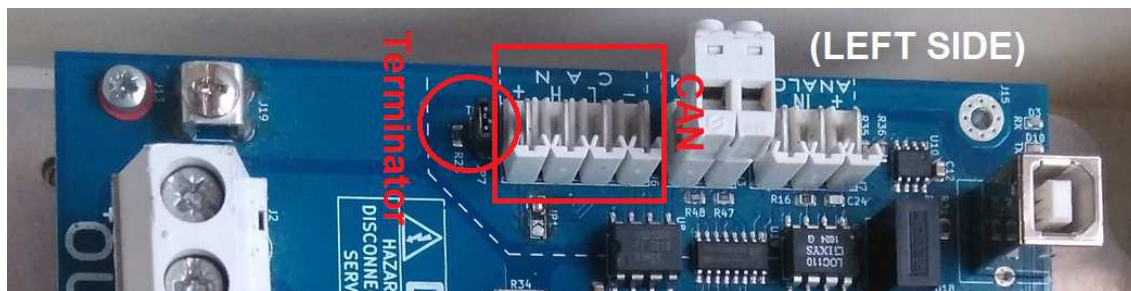

Can IDs:

PWS3.2b and PWS3.3 include a micro-switch block that allows to select up to 4 IDs

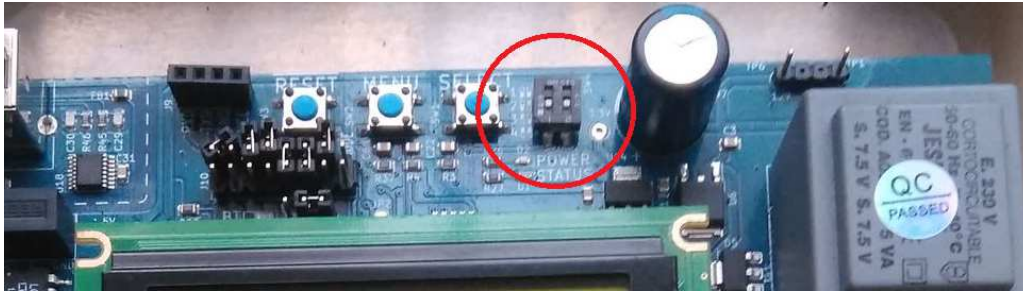

Position	ID	SP5	SP6
Low Low (default)	0x100	Front	F1
Low High	0x104	Rear	R1
High Low	0x108	-	F2
High High	0x10C	-	R2

CAN ID is shown during the startup to help to configure the system. These IDs are used by the SP5 / 6 to command the PWS, while 0x20n IDs (0x200 to 0x20C) are used for feedback.

The system allows up to 16 x PWS connected to the DAQ, all 16 PWS will share the 4 0x10n (0x100 to 0x10C) IDs, but each one will have a different feedback ID (0x200 to 0x23C) to allow to identify all 16 by separate. This configuration has to be stored by SportDevices with a specific tool. This process is only necessary when more than 4 PWS are necessary to be connected by CAN.

	SPx to PWS	PWS to SPx
#1	0x100	0x200
#2	0x104	0x204
#3	0x108	0x208
#4	0x10C	0x20C
#5	0x100	0x210
#6	0x104	0x214
#7	0x108	0x218
#8	0x10C	0x21C
#9	0x100	0x220
#10	0x104	0x224
#11	0x108	0x228
#12	0x10C	0x22C
#13	0x100	0x230
#14	0x104	0x234
#15	0x108	0x238
#16	0x10C	0x23C

Example for HUB-4 Configuration

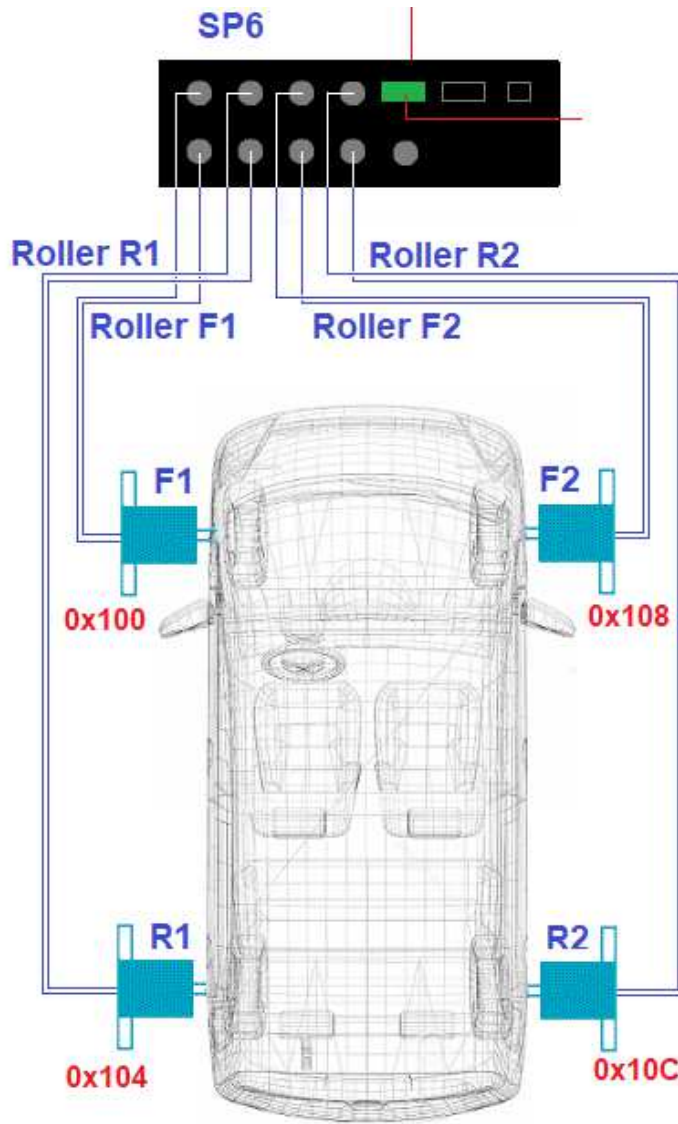

CAN Transceiver Power

PWS3.3b includes two jumpers to provide 5V to the isolated CAN transceiver. It is recommended to keep them in the upper position to get the power from the internal DC/DC instead from SP5/6 specially when there are more than 1 power supplies.

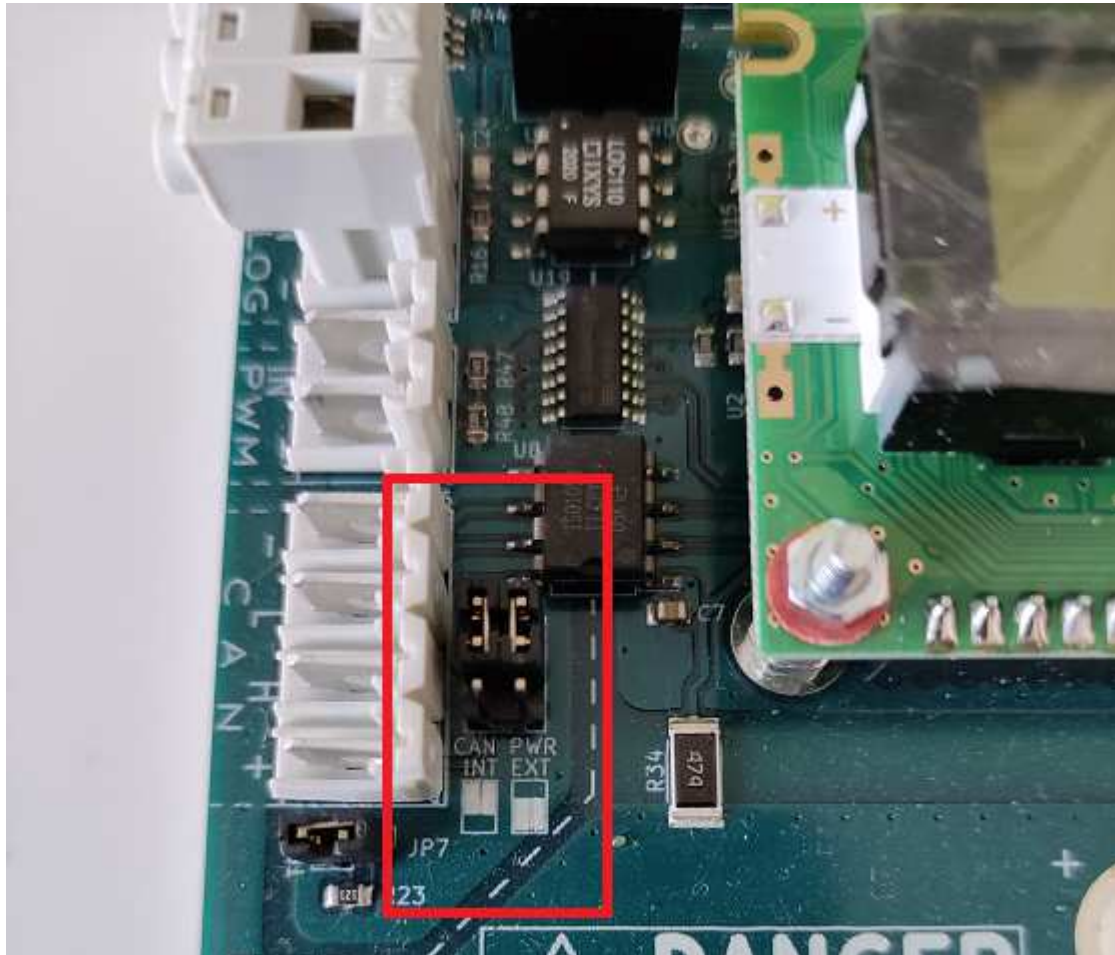

In the first **PWS3.3 units** (not PWS3.3b), the JP3 jumper should be set at the left side. And a small wire must exist between pins PWM- and GND- (it can be checked with a multimeter over those pins, without removing the PCB)

